



# PHOTOVOLTAIC TERRESTRIAL MODULE

## PRODUCT DATA SHEET

### APV-150/24 M

The **APV-150/24M** type photovoltaic terrestrial module is designed to provide superior value and performance for residential, commercial and industrial use. With time-tested mono silicon solar cells, it provides cost-effective power for DC loads or, with an inverter, AC loads. With 145 or 155 watts of nominal maximum power, it is used in utility-grid supplemental systems for residences, commercial buildings, and centralized power generation as well as in remote systems for applications including telecommunications, pumping and irrigation, remote villages and homes, and land-based aids to navigation.

#### Electrical Characteristics <sup>\*)</sup>

<b>Type of solar module</b>	<b>APV-150/24M</b>
Maximum power P <sub>max</sub> , Wt	150 ± 5
Voltage of open circuit Voc, V	43,5
Current of short circuit Isc, A	4,90
Voltage at maximum power V <sub>mpp</sub> , V	33,7
Current at maximum power I <sub>mpp</sub> , A	4,45
Temperature coefficients	TC(Voc) = -0,33 %/°C; TC(Isc) = +0,038 %/°C; TC(P) = -0,45 %/°C
Maximum system voltage, V	1000
Tolerance of parameters, % **	± 3

<sup>\*)</sup> All data at standard test conditions: Irradiance = 1000 W/m<sup>2</sup>; air mass = AM 1,5; T = 25 °C.

<sup>\*\*)</sup> Except maximum power.



#### Dimensions

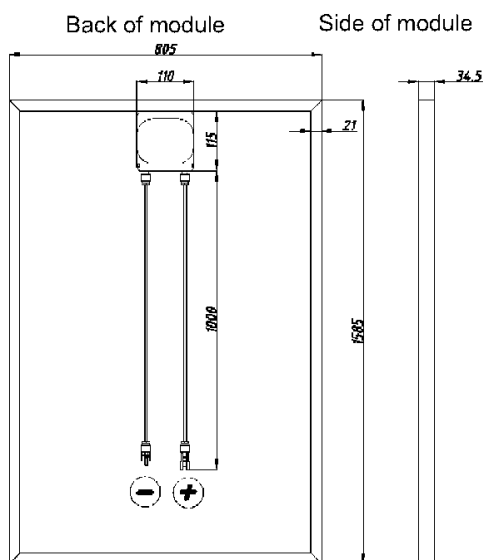

#### Intensity Dependence

Intensity W/m <sup>2</sup>	U <sub>mpp</sub> *	I <sub>mpp</sub> *
1000	1,00	1,0
800	0,99	0,8
200	0,95	0,2

\*Ratio of U<sub>mpp</sub>/I<sub>mpp</sub> at reduced intensity to U<sub>mpp</sub>/I<sub>mpp</sub> at 1000 W/m<sup>2</sup>

#### Technical Characteristics

Solar cell type	monocrystalline silicon. 72 pieces of 5 inch (pseudosquare)
Dimensions (mm)	1585x805x34.5
Connection box	Tyco with 3 bypass diodes IP 65
Cable Length:	100 cm each
Connector	Tyco solarlok
Weight	15,2



Certifications:  
ISOZERT. IEC 61215:2005  
(according to IEC 61730)

ASTON Engineering Ltd.

Renewable and uninterruptible power supply solutions

02097, Ukraine, Kiev, Balzaka str. 61A, of. 162, Tel. / fax +38 044 534 61 28, 353 05 09

Tel. +38 044 353 05 02, -04, -06, -08

web: [www.astoneng.com.ua](http://www.astoneng.com.ua), e-mail: [office@astoneng.com.ua](mailto:office@astoneng.com.ua)