



PHOTOVOLTAIC TERRESTRIAL MODULE

PRODUCT DATA SHEET

APV-170/24 M

The **APV-170/24M** type photovoltaic terrestrial module is designed to provide superior value and performance for residential, commercial and industrial use. With time-tested mono silicon solar cells, it provides cost-effective power for DC loads or, with an inverter, AC loads. With 167,5 or 172,5 watts of nominal maximum power, it is used in utility-grid supplemental systems for residences, commercial buildings, and centralized power generation as well as in remote systems for applications including telecommunications, pumping and irrigation, remote villages and homes, and land-based aids to navigation.

Electrical Characteristics *)

Type of solar module	APV-170/24M
Maximum power Pmax, Wt	170 ± 2,5
Voltage of open circuit Voc, V	44,3
Current of short circuit Isc, A	5,36
Voltage at maximum power V _{mpp} , V	35,25
Current at maximum power I _{mpp} , A	4,82
Temperature coefficients	TC(Voc) = -0,33 %/°C; TC(Isc) = +0,038 %/°C; TC(P) = -0,45 %/°C
Maximum system voltage, V	1000
Operating temperature, °C	- 40 ... +85
Tolerance of parameters, % **	± 3

*) All data at standard test conditions: Irradiance = 1000 W/m²; air mass = AM 1,5; T = 25 °C.

***) Except maximum power.

Dimensions

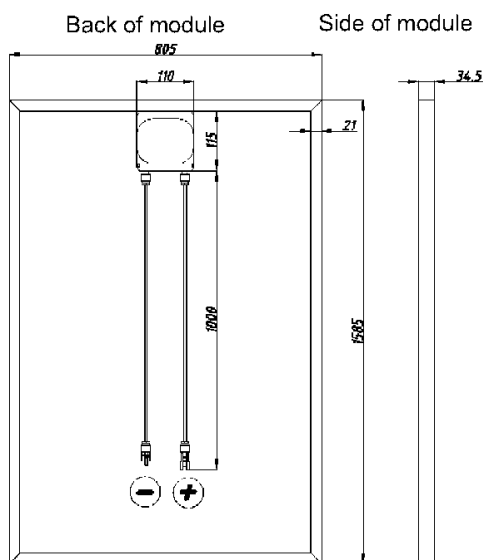

Intensity Dependence

Intensity W/m ²	U _{mpp} *	I _{mpp} *
1000	1,00	1,0
800	0,99	0,8
200	0,95	0,2

*Ratio of U_{mpp}/I_{mpp} at reduced intensity to U_{mpp}/I_{mpp} at 1000 W/m²

Technical Characteristics

Solar cell type	monocrystalline silicon. 72 pieces of 5 inch (pseudosquare)
Dimensions (mm)	1585x805x34.5
Connection box	Tyco with 3 bypass diodes IP 65
Cable Length:	100 cm each
Connector	Tyco solarlok
Weight	16,2
Front glass	4 mm



Certifications:
ISOZERT. IEC 61215:2005
(according to IEC 61730)

ASTON Engineering Ltd.

Renewable and uninterruptible power supply solutions

02097, Ukraine, Kiev, Balzaka str. 61A, of. 162, Tel. / fax +38 044 534 61 28, 353 05 09

Tel. +38 044 353 05 02, -04, -06, -08

web: www.astoneng.com.ua, e-mail: office@astoneng.com.ua